

VetroProf1

- Fibreglass double-sided rungs stepladder.
- Electrically isolation, stable and easy to use. Suitable for electricians and technicians.
- Light and not bulky.
- Aluminium die casting hinges.
- Possibility to add an aluminium die casting platform.

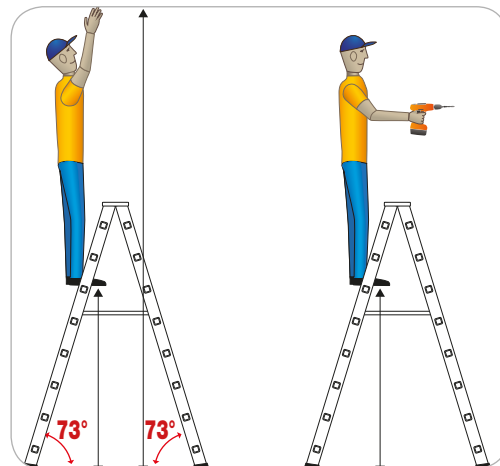

Aluminium die casting hinge with polyamide clutch insert to avoid the material wear and tear

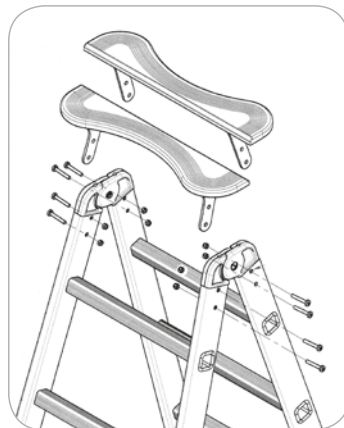

RIGHT WORKING POSITION

ACCESSORY: Aluminium die casting platform

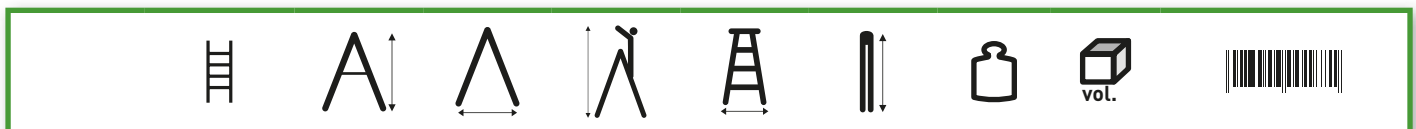

Code	rungs number	(cm)	(cm)	(cm)	(cm)	(cm)	(kg)	(m ³)	Ean
P1V-6	6	156,7	107,5	300	57,3	165,1	9,0	0,13	8028406080015
P1V-7	7	180,6	122,2	325	60,3	190,1	10,5	0,15	8028406080022
P1V-8	8	204,5	136,9	350	63,5	215,1	11,7	0,18	8028406080039
P1V-9	9	228,4	151,6	375	66,6	240,1	13,8	0,22	8028406080046
P1V-10	10	252,2	166,3	400	69,6	265,1	14,9	0,25	8028406080053
P1V-12	12	300,0	195,7	440	75,7	315,1	17,0	0,32	8028406080002

P1-SEL	ACCESSORY: aluminium die casting platform	8028406002260
--------	---	---------------

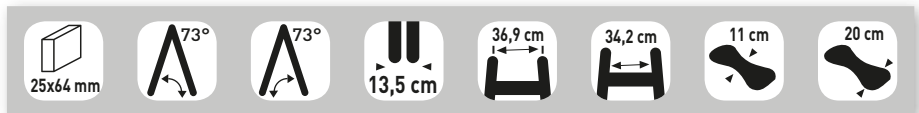

This product is delivered with a PVC wrap film and product leaflet



13,5
cm

150
kg
MAX



EN131
EUROPEAN NORM



EN 61478
CATEGORY
INSULATION
30 000 Volts

UPDATE NEW NORM EN131: 01/18



30x30 square non-slip rungs
on both sides



Pultrusion composed by
fibreglass and resin stratified
tissues

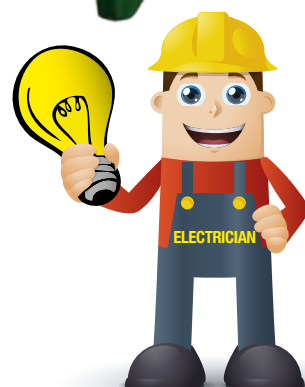

ELECTRICALLY
INSULATED
LADDER

