

# RAMPE di carico

KARGO SYSTEM serie di rampe per carico e scarico professionale di mezzi gommati.

CON SPECIALI LEGHE DI ALLUMINIO



## FISSAGGIO

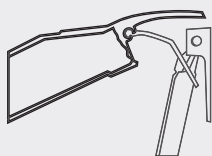

A- Con accessorio di bloccaggio **ABR** inserito tra il pianale e la sponda ribaltata

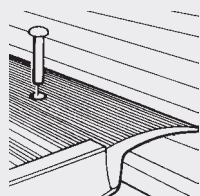

B- Con foro Ø 12 mm al centro dello sbarco. Forare anche il piano di carico e bloccare con spina



Accessorio di bloccaggio **ABR**

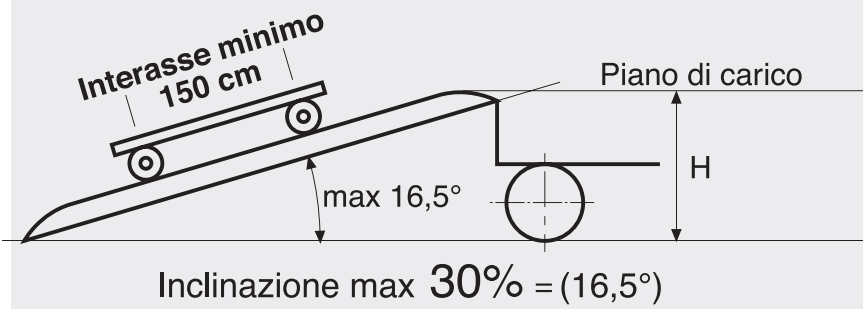

## LA GIUSTA RAMPA

$$\text{LUNGHEZZA RAMPE} = \frac{\text{Altezza Piano (in cm)} \times 30 \times 100}{\text{in cm} \quad 1000}$$

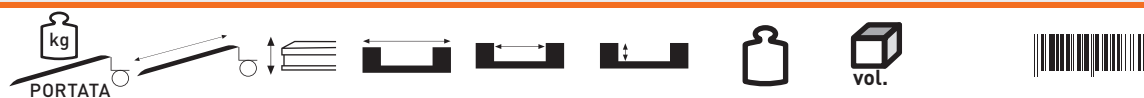

	Codice	Portata a coppia	(cm)	(cm)	(cm)	(cm)	(cm) h bordo	Peso cad.	(m <sup>3</sup> )	Codice Ean
<b>SERIE LEGGERA</b>	<b>RL30/15</b>	1.600	152	7,5	30	24	-	9,5	0,03	8028406000594
	<b>RL30/20</b>	1.400	197	7,5	30	24	-	12,4	0,04	8028406000600
	<b>RL30/25</b>	1.200	242	7,5	30	24	-	14,9	0,05	8028406000617
	<b>RL30/30</b>	1.000	302	7,5	30	24	-	18,3	0,07	8028406000624
	<b>RL30/35</b>	750	347	7,5	30	24	-	20,8	0,08	8028406000631
	<b>R1/18</b>	2.000	300	10,5	37	30	3,0	24	0,12	8028406000648
	<b>R2/15</b>	1.800	350	10,5	37	30	3,0	28	0,14	8028406000655
	<b>R3/13</b>	1.500	400	10,5	37	30	3,0	32	0,16	8028406000662
	<b>R4/39</b>	4.600	300	13,5	41	32	3,5	36	0,17	8028406000679
	<b>R5/31</b>	3.700	350	13,5	41	32	3,5	41	0,19	8028406000686
	<b>R6/26</b>	3.100	400	13,5	41	32	3,5	47	0,22	8028406000693
	<b>R7/54</b>	6.200	300	15	50	40	2,0	49	0,23	8028406000709
	<b>R8/44</b>	5.200	350	15	50	40	2,0	59	0,26	8028406000716
	<b>R9/36</b>	4.200	400	15	50	40	2,0	65	0,30	8028406000723
	<b>ABR</b>	Accessorio in acciaio per fissaggio rampa (tra sponda e cassone)								8028406000730



UNI 8634 - DIN 15126



Leggere, di facile  
movimentazione manuale



Spalla portante

Ideali per  
carico e scarico  
professionale di  
mezzi gommati

