

# VetroProf1

- Fibreglass double-sided rungs stepladder.
- Electrically isolation, stable and easy to use. Suitable for electricians and technicians.
- Light and not bulky.
- Aluminium die casting hinges.
- Possibility to add an aluminium die casting platform.

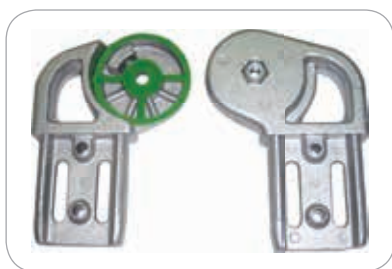

Aluminium die casting hinge with polyamide clutch insert to avoid the material wear and tear

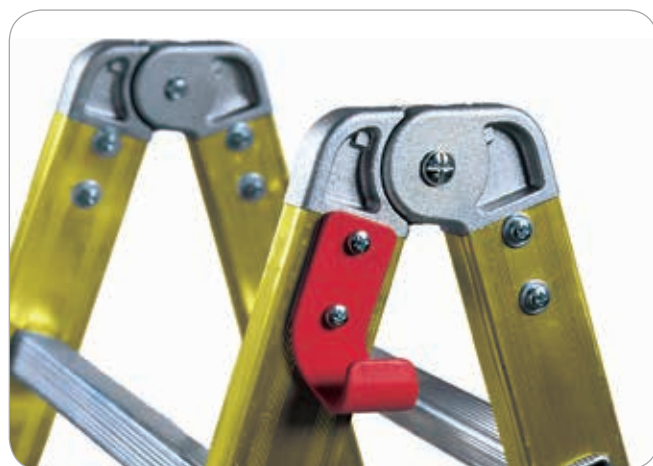
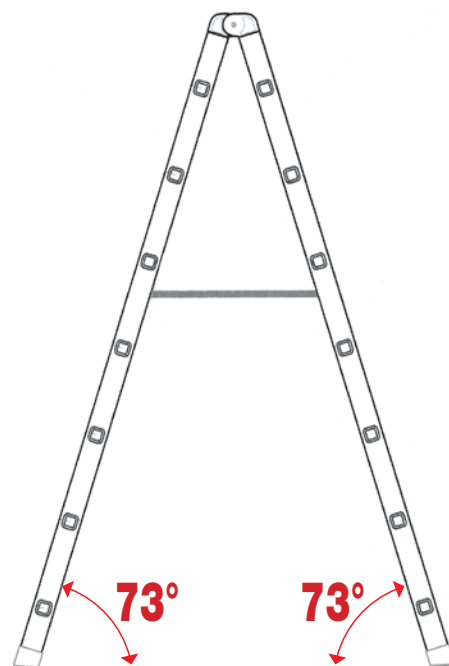
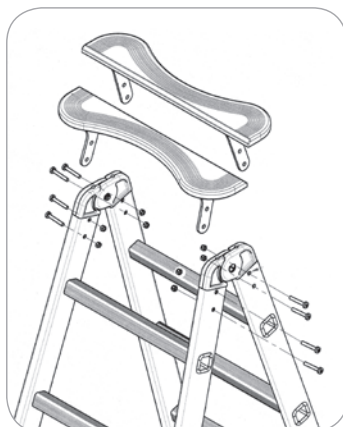

ACCESSORY: Aluminium die casting platform

WORK SLOPE AT 73° ON BOTH SIDES

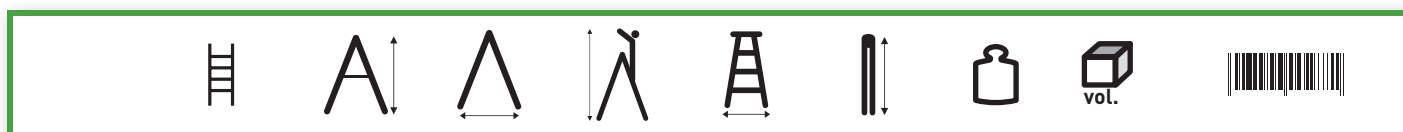

Code	rungs number	(cm)	(cm)	(cm)	(cm)	(cm)	(kg)	(m <sup>3</sup> )	Ean
P1V-6	6	156,7	107,5	300	57,3	165,1	9,0	0,08	8028406080015
P1V-7	7	180,6	122,2	325	60,3	190,1	10,5	0,09	8028406080022
P1V-8	8	204,5	136,9	350	63,5	215,1	11,7	0,11	8028406080039
P1V-9	9	228,4	151,6	375	66,6	240,1	13,8	0,12	8028406080046
P1V-10	10	252,2	166,3	400	69,6	265,1	14,9	0,14	8028406080053
P1V-12	12	300,0	195,7	440	75,7	315,1	17,0	0,16	8028406080002

P1-SEL ACCESSORY: aluminium die casting platform 8028406002260

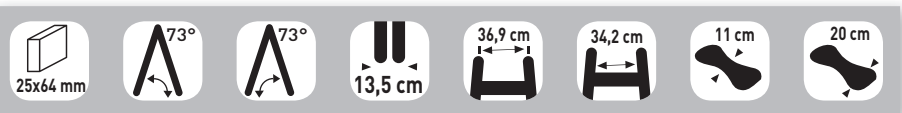

*This product is delivered with a PVC wrap film and product leaflet*



13,5  
cm

150  
kg  
MAX



EN131  
EUROPEAN NORM



2006/4882



30x30 square non-slip rungs on both sides



Pultrusion composed by fiberglass and resin stratified tissues

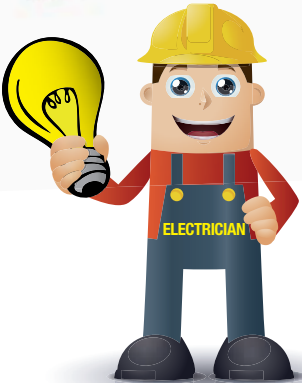

ELECTRICALLY INSULATED LADDER

